

Condition Monitoring and Diagnosis of Faults in the Electric Induction Motor

¹A. Medoued, ¹A. Metatla, ¹A. Boukadoum, ²T. Bahi and ²I. Hadjadj

¹Department of Electrotechnics,

Faculty of Science of the Engineer, University of Skikda, Algeria

²Department of Electrotechnics,

Faculty of Science of the Engineer, University of Annaba, Algeria

Abstract: Problem statement: The diagnosis of failures in the induction machine, when it is implemented effectively and whether it allows detecting early deterioration of the system, represents a means to help achieve better productivity. **Approach:** Primary purpose was to detect and locate a possible malfunction of equipments. In this study we developed a method using the three phase-biphas transformation (shape recognition), based on a two-dimensional representation of the three-phase components of the stator current and rotor flux. This approach was a static approach, considering the necessity to make several recordings of signals. **Results:** In this study we considered defect type in the induction machine with broken rotor bars. We presented signatures of the stator current and rotor flux for the healthy model complete and permanent regime, and then the signatures of the same quantities in continuous operation and complete regime for the model with short circuit and broken bars failure. **Conclusion/Recommendation:** Systems of diagnosis must be conceived to support many procedures of test starting ones the others and often functioning in parallel and different places.

Key words: Induction motor, modelling, sensorless, diagnosis, detection

INTRODUCTION

With the development of the modern methods of the diagnosis in order, the state space modeling of the induction machine proves to be essential. The control sensorless makes it possible to improve the robustness, the reliability of the machine and to reduce the cost of the systems. The induction machines remains very appreciated in the industrial world because their applications requiring a higher dynamic performance.

Different works on the real time estimation of the sizes and the parameters have been accomplished. However, the techniques based on Luenberger and Kalman observers require a model of state of the induction machine.

In this study, we present a generalized state space of the induction machine in an arbitrary reference frame. The state variables are: the stator current and rotor flux. Due to the principle of field orientation^[1], this model can be reduced. A comparative study of the complete model and small-scale model are presented and the alternatives linear and nonlinear as well as the estimation possibility of the rotor resistance are also discussed.

Modeling of the asynchronous machine: The induction motor is a nonlinear and nonstationary system. The complexity of such a model can be simplified by using Park transformation and the field orientation techniques. The state space modeling of the induction motor in an arbitrary reference is given by^[1]:

$$\frac{d}{dt} \Psi = \Omega \Psi - RI + I_0 U \quad (1)$$

$$\Psi = L_M I \quad (2)$$

Where:

$$\Psi = [\Psi_s \quad \Psi_r]^T$$

$$I = [i_s \quad i_r]^T$$

$$U = [u_s \quad u_r]^T$$

With:

Ψ = The vector of flux

I = The vector of current

U = The vector of voltage

Matrices Ω , R , I_0 and L_M are defined by:

$$\Omega = \begin{bmatrix} \Omega_a & 0_2 \\ 0_2 & \Omega_{ar} \end{bmatrix}$$

With:

$$\Omega_a = \begin{bmatrix} 0 & \omega_a \\ -\omega_a & 0 \end{bmatrix}$$

$$\Omega_{ar} = \begin{bmatrix} 0 & (\omega_a - \omega_r) \\ -(\omega_a - \omega_r) & 0 \end{bmatrix}$$

and

$$R = \begin{bmatrix} R_s & 0_2 \\ 0_2 & R_r \end{bmatrix}$$

With:

$$R_s = \begin{bmatrix} r_s & 0_2 \\ 0_2 & r_s \end{bmatrix}$$

$$R_r = \begin{bmatrix} r_r & 0_2 \\ 0_2 & r_r \end{bmatrix}$$

$$L_M = \begin{bmatrix} L_s & M \\ M & L_r \end{bmatrix}$$

With:

$$L_s = \begin{bmatrix} l_s & 0_2 \\ 0_2 & l_s \end{bmatrix}$$

$$L_r = \begin{bmatrix} l_r & 0_2 \\ 0_2 & l_r \end{bmatrix}$$

$$M = \begin{bmatrix} m & 0_2 \\ 0_2 & m \end{bmatrix}$$

and finally

$$I = \begin{bmatrix} I_2 & 0_2 \\ 0_2 & 0_2 \end{bmatrix}$$

The lemma of matrix inversion is used to simplify calculations and facilitate the transformation of the various dynamic models of the asynchronous machine. Let's have the expression of the inversion of L_M :

$$L_M^{-1} = \begin{bmatrix} (L_s - ML_r^{-1}M^T)^{-1} & -(L_{sr} - ML_r^{-1}M^T)^{-1}ML_r^{-1} \\ -(L_r - M^TL_s^{-1}M)^{-1}M^TL_s^{-1} & (L_r - M^TL_s^{-1}M)^{-1} \end{bmatrix} \quad (3)$$

According to the Wamkeue and Kamwa^[2] marks of reference and choice's of the variables of different state models are possible. Among these models, we consider the case where the stator current and rotor flow are the variables of state. Thus, the model is written:

$$\frac{d}{dt} \begin{pmatrix} i_s \\ \phi_r \end{pmatrix} = \begin{bmatrix} a_{11} & a_{12} \\ -R_s & \Omega_a \end{bmatrix} \begin{pmatrix} i_s \\ \phi_r \end{pmatrix} + \begin{bmatrix} b_{11} \\ I_2 \end{bmatrix} u_s \quad (4)$$

$$\frac{d\omega_r}{dt} = \frac{P}{J}(T_e - T_l) \quad (5)$$

$$T_e = \text{pi}_s^T \begin{bmatrix} 0 & -1 \\ 1 & 0 \end{bmatrix} \phi_s \quad (6)$$

$$\begin{pmatrix} i_r \\ \phi_r \end{pmatrix} = \begin{bmatrix} -M^{-1}L_s & M^{-1} \\ (M - L_rM^{-1}L_s) & L_rM^{-1} \end{bmatrix} \begin{pmatrix} i_s \\ \phi_s \end{pmatrix} \quad (7)$$

The parameters of the matrix of evolution are:

$$a_{11} = \Omega_{ar} + (M - L_rM^{-1}L_s)^{-1}(R_rM^{-1}L_s + L_rM^{-1}R_s)$$

$$a_{12} = (M - L_rM^{-1}L_s)^{-1}[(\Omega_sL_r - R_r)M^{-1} - L_rM^{-1}\Omega_a]$$

$$\text{et } b_{11} = -(M - L_rM^{-1}L_s)^{-1}L_rM^{-1}$$

Note: The case of the nonlinear model can be obtained by regarding the number of revolutions as an additional variable of state.

Technique of estimate of state: Let us have a continuous system described by the equation of deterministic state as follows:

$$\dot{x}(t) = Ax(t) + Bu(t) \quad (8)$$

$$\dot{y}(t) = Cx(t) + Du(t) \quad (9)$$

where, $u(t)$, $y(t)$ and $x(t)$ are vectors of dimension m , L and n which respectively represent the control, the measured output and the state of the system. Matrices A , B , C and D are constant matrices of suitable size^[3]. As generally, the state is not accessible, the objective of an observer consists in estimating this state by a variable which we will note $\hat{x}(t)$. This estimate is carried out by a dynamic system whose output will be precisely $\hat{x}(t)$ and the input will be consisted of the whole of information available, i.e., $u(t)$ and $y(t)$.

The structure form of observer is:

$$\hat{x}(t) = A\hat{x}(t) + Bu(t) + L(y(t) - \hat{y}(t)) \quad (10)$$

$$\hat{y}(t) = C\hat{x}(t) + Du(t) \tag{11}$$

where, appears clearly on one hand the corrective term $y(t) - \hat{y}(t)$, according to the error of rebuilding of the output, on the other hand, the profit of correction (L), called profit of the observer which one must determine.

This structure can be written in the following equivalent form:

$$\dot{\hat{x}}(t) = (A - LC)\hat{x}(t) + (B - LD)u(t) + Ly(t) \tag{12}$$

If one considers the error in estimation: $\tilde{x}(t) = x(t) - \hat{x}(t)$, then one obtains:

$$\dot{\tilde{x}}(t) = (A - LC)\tilde{x}(t) \tag{13}$$

In this case, a great freedom is left with the choice of the eigenvalues, but in practice one chooses a dynamics of error faster than that of the process in the case of an observation in open loop or than that desired in closed loop [4]. However, one cannot take them infinitely large for two essential reasons:

- One can use only realizable profits
- The increase in the band-width of the reconstructor does not make it possible any more to neglect the noises which become dominating in high frequency

The physical complexity of the asynchronous machines is related to the electromagnetic interactions between the stator and the rotor. The sizes of state or output used for the development of the order or the monitoring of the motorized systems are often difficult to reach for technical reasons or problems from cost problems [5-7]. Therefore, It is necessary to determine starting from the already measured sizes (current, tension...), without using dedicated sensors.

They can be reconstituted by traditional estimators used in open loop or observers correcting in closed loop the estimated variables.

The technique of the estimators rests on the use of a representation of the machine in the form of state defined in the reference mark of park. In steady operation (static estimator) or transient (dynamic estimator), they are obtained by direct resolutions of the equations associated with the model.

For using a system in a chain of control it is first of all necessary to study its conditions of observability and commandability. These two concepts use also the model of state of the asynchronous machine.

Application of the observers of state with the monitoring: In addition to the rebuilding of the state to work out a control by return of state, we will see here

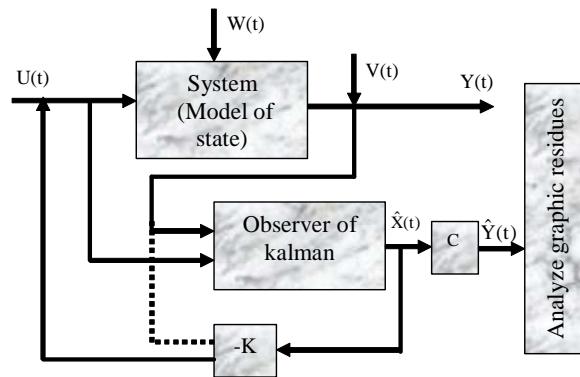

Fig. 1: Principle of the observation, controls, surveillance

another significant application of the observers in control, detection and diagnosis of the failures [6] in the electric machines. In this optics, one uses the observer to generate residues allowing to working out a decision in a stage of monitoring of the system during the appearance of the disturbances or the defects [8-10]. The variables which act on the system cannot be measured; therefore the objective of the observer consists in building residues which, according to cases, must be sensitive to the defects and insensitive with the disturbances.

In all the methods of detection of the failures suggested in the literature [11-14], one must take one or more signals to treat them, analyze them and conclude, with certainty, if there is a failure or not.

With this intention, four elementary signals can be taken. It is about the stator current, of the radiating flux of the machine, the vibrations number of revolutions. But in our case, it is enough to measure the stator current, since it is a diagnosis without sensors or more exactly a diagnosis with a minimum of sensors.

The control and monitoring principle without sensors is shown by Fig. 1.

Figure 1 introduced the principle of operation of an observer Kalman, or U(t) presented the input signal and Y(t) signal output and W(t) and V(t) is the state noise and noise measurement. $\hat{x}(t)$ and $\hat{y}(t)$ are the status and estimated output respectively.

MATERIALS AND METHODS

To highlight the performances of the suggested technique of monitoring we consider an induction motor with parameters shown in Table 1. Simulation consists in studying the dynamic performances of the induction machine in the space of state by using MATLAB software to see the possibilities of detection without sensors.

Table 1: Machine parameters

Sizes	Values	Units
Frequency	50.000	Hz
Voltage	220.000	Volts
Resistance of the stator	0.630	Ohms
Resistance of the rotor	0.400	Ohms
Inductance of the stator	0.097	Henry
Inductance of the rotor	0.091	Henry
Mutual inductance	0.091	Henry
Moment of inertia	0.220	Kg m ²
Rotor pulsation	146.600	Rd sec ⁻¹

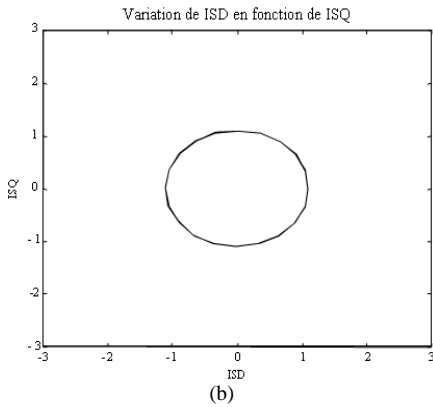
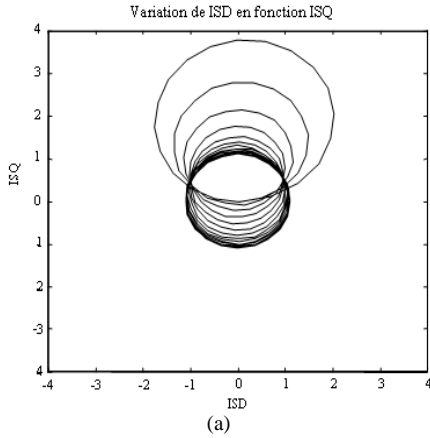

Fig. 2: Variation of the stator currents

RESULTS AND DISCUSSION

Results of simulation of the healthy model and the defective model are shown in Fig. 2-7. However, the symbols (a) and (b) in Fig. 2-7 represent a simulation of the complete and the steady system respectively.

Figure 2 and 3 respectively shows the evolution of current and rotor flux in healthy case, but the estimations of these quantities are also shown in Fig. 4 and 5. It is clearly seen that the homologous curves are indisputably identical, which validates the adopted estimating method.

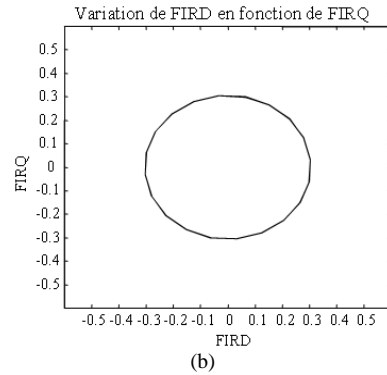
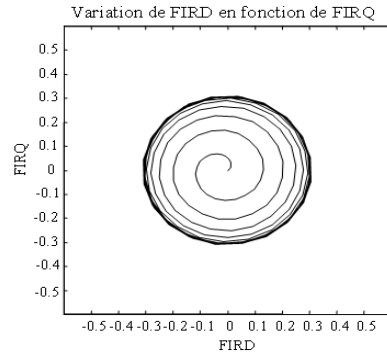

Fig. 3: Variation of rotor flux

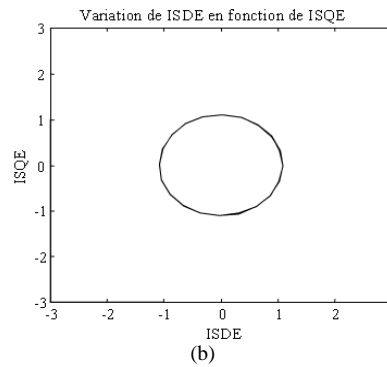
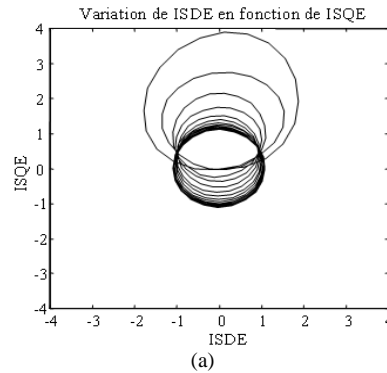

Fig. 4: Variation of the currents of the stator estimated

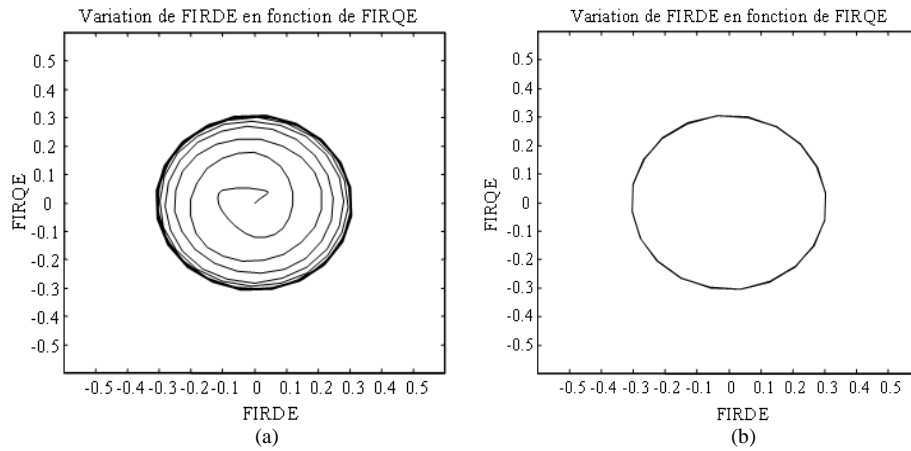

Fig. 5: Variation of fluxes of the rotor estimated

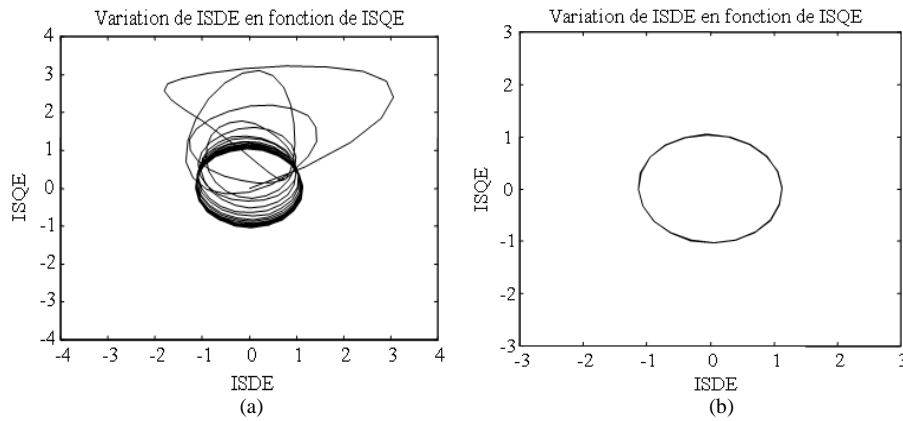

Fig. 6: Variation of the estimated stator currents with default

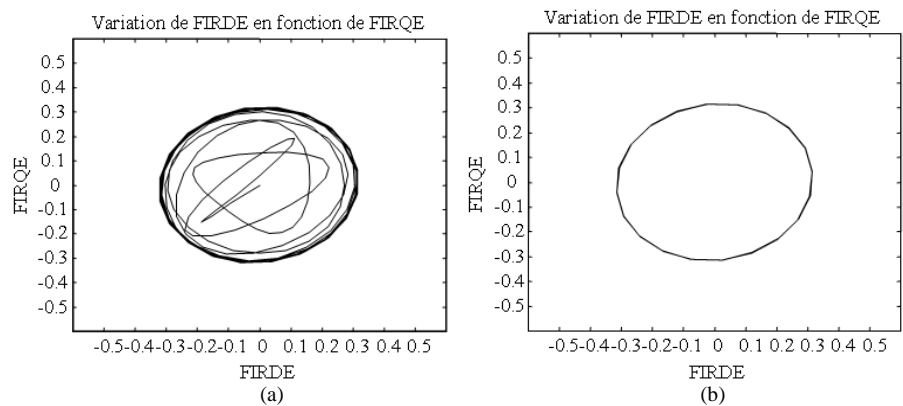

Fig. 7: Variation of estimated rotor flux with default

Figure 6 and 7 show the signature of the phase shift on the Lissajou curve. This signature enables us to

easily determine the nature of defect (broken bars) due to the curve's shape.

To this end, it is enough to make recordings of the estimated variables of state of the motor and to make a comparison with the estimated results in the case of failure by using the analysis of Lissajou curves or the spectral analysis.

We notice that these tests represent only the results obtained by the estimated current and flux analysis, however, the alternative of analyzing other variables as the electromagnetic couple is also possible.

CONCLUSION

The industrial systems have become increasingly sophisticated with on one hand the numerical systems of control and on the other hand the technological solutions for distributed and hierarchical data processing. Because of these evolutions, the establishment of algorithms of diagnosis within industrial facilities became possible. So that the methods of diagnosis can apply to complex systems, it is crucial to conceive adapted methodologies and technologies. The systems of diagnosis must be conceived to support many procedures of test starting ones the others and often functioning in parallel and different places. On a higher level, the results of the test of detection must be analyzed to lead to a reliable holding diagnosis.

REFERENCES

1. Blaschke, F., 1970. The principle of field orientation as applied to the new TRANSVEKTOR closed loop control system for rotating-field machines. *Siemens Rev.*, 39: 217-220.
2. Wamkeue, R. and I. Kamwa, 1999. Generalised state space modelling of induction machines having multiple rotor circuits. *Proceedings of the 3rd International Symposium on Advanced Electromechanical Motion Systems, Patras, Greece*, pp: 61-66.
3. Bensaker, B., 1999. Parameter estimation for an electromechanical system via a continuous-time model. *Proceedings of the 3rd International Symposium on Advanced Electromechanical Motion Systems, University of Patras, Greece*, pp: 759-762.
4. Metatla, A., A. Maouche and B. Bensaker, 2003. Application of the observer techniques to controlling sensorless induction motors SNSEM University of Annaba. Algeria.
5. Bensaker, B., A. Maouche, A. Metatla and H. Kherfane, 2004. Sensorless control and monitoring of induction motor. *Proceeding of the 2nd International Symposium of Hydrocarbons and Chemistry, Ghardaia, Algeria. Mar. 21-23.*
6. Moreau, S., J.C. Trigeassou, G. Champenois and J.P. Gaubert, 1999. Diagnosis of induction machines: A procedure for electrical fault detection and localization. *IEEE International SDEMPED'99, Gijon, Espagne*, pp: 225-230.
7. Holtz, J., 2002. Sensorless control of induction motor drives. *Proc. IEEE*, 90: 1359-1394. DOI: 10.1109/JPROC.2002.800726
8. Pana, T., 1999. Speed sensorless induction drive system for direct driven electrical vehicle. *Proceedings of the 3rd International Symposium on Advanced Electrical Motion Systems, Patras, Greece*, pp: 829-834.
9. Bodson, M. and J. Chiasson, 2002. Comparison of sensorless speed estimation methods for induction motor control. *Proceedings of the Conference on American Control, May 8-10, IEEE Xplore Press, USA.*, pp: 3076-3081. http://ieeexplore.ieee.org/xpls/abs_all.jsp?arnumber=1025261
10. Toliyat, H.A. and T.A. Lipo, 1995. Transient analysis of cage induction machines under stator, rotor bar and end ring faults. *IEEE Trans. Energ. Convers.*, 10: 241-247. DOI: 10.1109/60.391888
11. Bellini, A., F. Filippetti, G. Francsehini, C. Tassoni and G.B Kliman, 2001. Quantitative evaluation of induction motro broken bars by means of electrical signature analysis. *IEEE Trans. Ind. Appl.*, 37: 1248-1255. DOI: 10.1109/28.952499
12. Trzynadlowski, A.M. and E. Ritchie, 2000. Comparative inversigation of diagnostic media for induction motors: A case of rotor cage. *IEEE Trans. Energ. Convers.*, 47: 1092-1099. DOI: 10.1109/41.873218
13. Bachir, S., S. Tnani, J.C. Trigeassou and G. Champenois, 2006. Diagnosis by parameter estiamtion of stator and rotor faults occuring in induction machines. *IEEE Trans. Ind. Elect.*, 53: 963-973.
14. Casimir, R., 2003. Diagnosis of Asynchronous Machines Defaults using forms Recognition. Doctoral thesis in French. Lyon, France.